

RiPower GmbH

Firmenvorstellung + Produkte

Präsentation am 28.06.2018 - Fachkonferenz :
„Alternative Antriebe auf den Gewässern“

Sven Richter

Gliederung

1. Vorstellung
2. Firmengeschichte
und Projekte
3. Produkte und
Dienstleistungen

The logo for RIPPOWER is displayed in a stylized, blue, 3D font with a white outline and a slight shadow. It is centered on a white rectangular background that is tilted and appears to be a page from a document or book, with a shadow underneath. The background of the entire slide has a light blue and white dot grid pattern.

RIPPOWER

1. Vorstellung

- Sven Richter
- Elektrotechniker
- auf dem Wasser seit der Geburt
- Schlauchboote, Motorboote, Segelboote
- Antriebstechnik als Hobby
- Selbständig seit 2009









2. Firmengeschichte

- 1960 Heinz Rieche
- 2009 Sven Richter
Einzelunternehmen
- 2010 RiPower –
elektrische
Antriebssysteme
- 2017 RiPower + Reifen &
KFZ-Service Weidlich =
RiPower GmbH

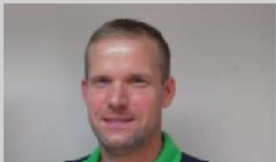

- 2 Geschäftsführer
- 3 Mitarbeiter
- 6 Fremddienstleister

		
<p>Geschäftsführer: Sven Richter</p> <p>technische Entwicklung und Bootstechnik</p>	<p>Geschäftsführer: Jörg Krüger-Weidlich</p> <p>KFZ-Meister / Fahrzeugtechnik</p>	<p>Dipl.-Ing. Eckhard-Weidlich</p> <p>Fahrzeugtechnik</p>
		
<p>Daniel Quasnitschka</p> <p>Social-Media, Mechanik, Elektro- und Bootstechnik</p>	<p>Thomas Schindler</p> <p>Fahrzeugtechnik</p>	<p>Telefonannahme und Kundenbetreuung</p> <p>Laura Besler Saskia Syndikus Dagmar Dworschak</p>

Elektroauto-Tankstelle seit 2007



E-Bike, 1500W, 60 km/h



Elektro-Quad zum
Rangieren von Booten



Elektro-Pickup, 280 PS,
800 Nm Drehmoment,
Reichweite 300 km



















3. Produkte & Dienstleistungen

- Elektrische Bootsantriebe (Innenborder und Aussenborder)
- Elektrische Fahrzeugantriebe
- Lithium-Speichertechnik
- Elektroboote
- Entwicklungsarbeit (Bsp. Android-Autopilot)



Elektrische Bootsantriebe

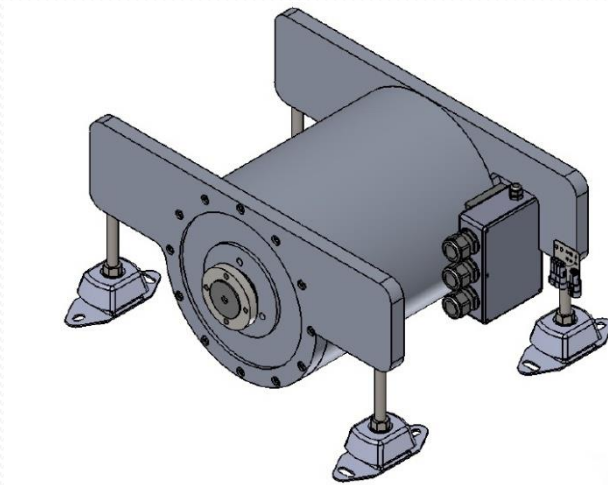

Elektrische Fahrzeugantriebe



Lithium-Speichertechnik



Elektroboote - Komplettpakete



Elektroboote – aktuelles Projekt

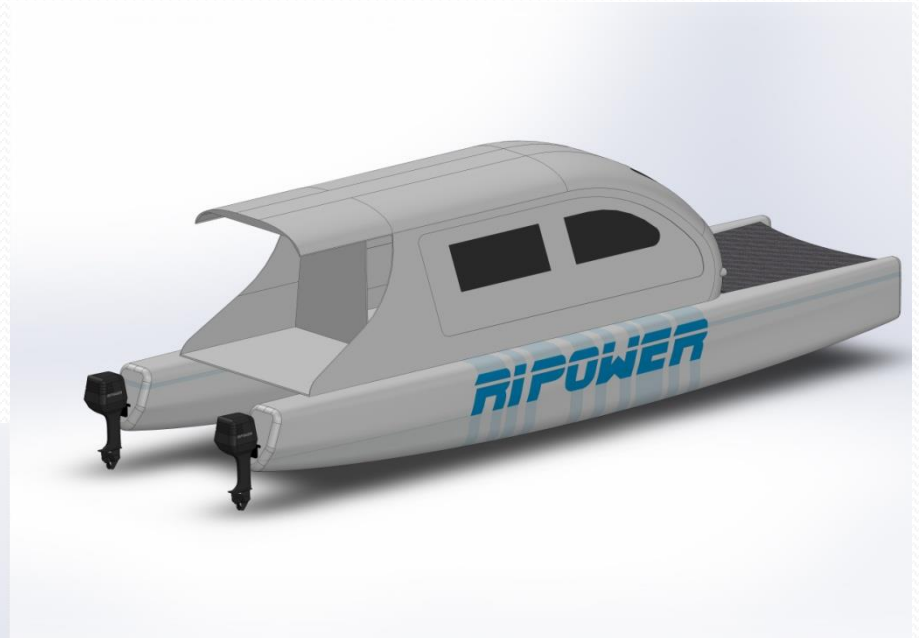

Entwicklungsarbeit





Vielen Dank für Ihre
Aufmerksamkeit !

www.ripower.de